

Project:	Type:
	Comments:



Highlights

Dual-Dimming Architecture: Phase dimming (Forward phase, MLV, Reverse phase, ELV, TRIAC) and 0-10V dimming (0-10V/1-10V/Potentiometer/10V PWM 4-in-1) compatible.

Ultra-Smooth Dimming: Full 0-100% dimming range with an industry-leading dimming depth of 0.1% and completely flicker-free performance.

Robust Environment Performance: Driver built-in Junction Box; IP-rated enclosure suitable for dry, damp, and wet locations.

Power Efficiency: Built-in active PFC function achieving high power factor (PF > 0.9) and an overall efficiency up to 88%.

Full Certifications: cULus Listed (E495946), FCC Class 2, TYPE HL, SELV, RoHS, and REACH compliant.

Project:	Type:
	Comments:

Configuration Example

Model #
TECHOLED-MT-24

Ordering Guide:

Select one option from each group below. For a custom preference please contact sales@techoled.com

1-FAMILY	2-DC OUTPUT VOLTAGE	3-OUTPUT POWER
MT-D DRIVER	12 12(VDC)	300 (300W)
	24 24(VDC)	
	48 48(VDC)	

Project:	Type:
	Comments:

Model	MT-12	MT-24	MT-48	
Certificate	UL / cUL / FCC / TYPE HL / SELV / RoHS / REACH			
Output	DC Voltage	12V	24V	48V
	Voltage Tolerance	±0.5V		±1V
	Voltage Regulation	±0.5%		
	Rated current	25A	12.5A	6.25A
	Rated power	150W		
	Load Regulation	±2%	±1%	±1%
Input	Voltage Range	100-277VAC		
	Frequency Range	50 / 60Hz		
	Power Factor @ full load	>0.9		
	THD(Typ.) @ full load	<20%@120VAC & 277VAC		
	Efficiency(Typ.) @ full load	≥87%@120VAC ≥89%@277VAC	≥88%@120VAC ≥91%@277VAC	≥88.95%120VAC ≥91.75%@277VAC
	AC Current (Max.)	3.4A		
	Inrush Current (Typ.)	20A, 1.9ms @50% 120VAC	35A, 1.9ms @50% 277VAC	
	Leakage current	<0.5mA		
Protection	Short Circuit	Shut down o/p voltage, re-power on to recover after fault condition is removed. Or, hiccup mode, automatically recovers after fault condition is removed.		
	Over Load	12V&24V: 105%~125% Constant current mode, automatically recovers after fault condition is removed. 48V: 105%~125% Hiccup mode, automatically recovers after fault condition is removed.		
	Over temperature	Shell surface temp.100°C±10°C shut down o/p voltage, re-power on to recover after fault condition is removed. Or, hiccup mode, automatically recovers after fault condition is removed.		
Environment	Working TEMP. (Ta)	-40~+45°C (see below derating curve)		
	Case Temperature (Tc)	90°C		
	Working Humidity	20 - 95%RH non-condensing		
	Storage TEM.,Humidity	-40 - +80°C,10 - 95% RH non-condensing		
	TEMP.coefficient	±0.03%/°C(0 - 50°C)		
	Vibration	10~500Hz, 5G 12min./1 cycle, period for 72min. each along X,Y,Z axes		
Safety & EMC	Safety standards	UL8750; CAN/CSA-C22.2 No. 250.13		
	Withstand voltage	I/P-O/P: 1.88KVAC I/P-FG: 1.88KVAC O/P-FG: 0.5KVAC		
	Isolation resistance	I/P-O/P: 100MΩ/ 500VDC/ 25°C/ 70% RH		
	EMC Immunity	FCC/ICES do not request this test.		
	EMC Emission	FCC 47 CFR Part 15, Subpart B		
Others	Net Weight	2.18KG		
	Dimension	10.9x4.33x1.92in(L*W*H)		
	Packing	13.4x11.6x9.84in 10pcs/CTN		
Notes	<ol style="list-style-type: none"> All parameters NOT specially mentioned are measured at 120VAC input, rated load, non-dimming state and 25°C of ambient temperature. Tolerance: includes set up tolerance and load regulation. 			

Project:	Type:
	Comments:

Dimensions

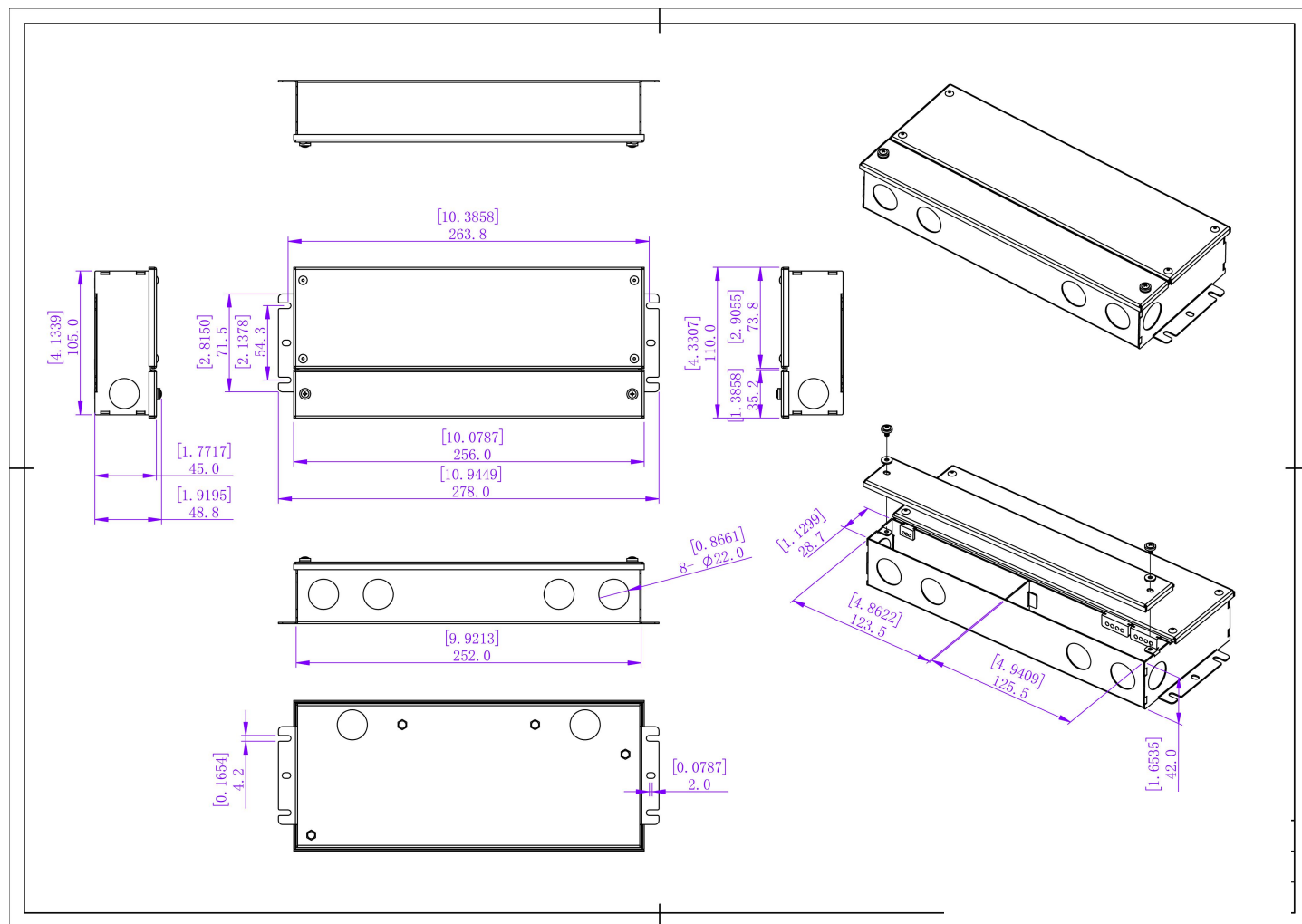

12V&24V&48V Version

Wire gauge	
JM98-2-A1	
Input wire	Black(L) White(N) Green(G)(3*18AWG)
Output wire	Red(V+) Black(V-)(2*14AWG)
Dimming wire	Purple(D+) Pink(D-)(2*18AWG)
Remarks: Please make sure your connect these correctly otherwise your product will not function correctly and could be damaged.	

Project:	Type:
	Comments:

DIMMING OPERATION AND CONNECTING DIAGRAM

Using two ways of dimming at the same time: You must be assured that LED lighting is up to the max. brightness, then you could operate with the other dimming style.

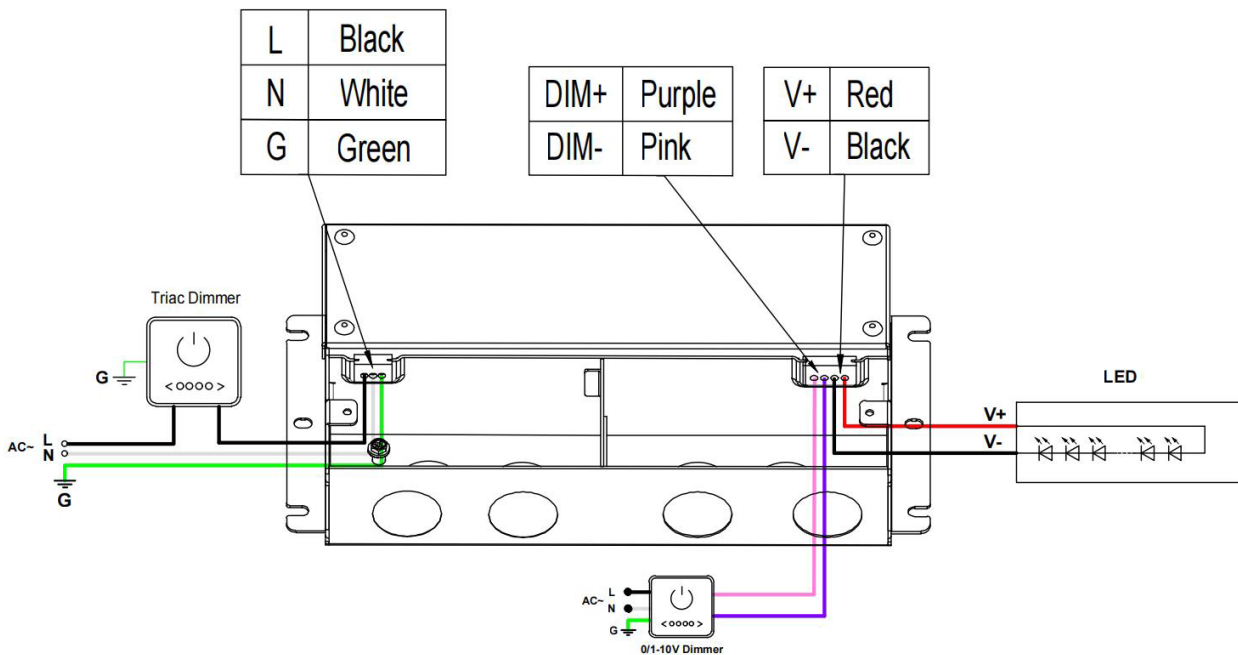

Using one dimming — TRIAC/Phase cut dimming

1. The Pulse-Width Modulation (PWM) of output voltage can be adjusted through the input terminal of the AC phase line (L) by connecting a phase / Triac dimmer or lighting system.
2. Working with Forward phase, MLV and Reverse phase, ELV, TRIAC dimmers or light systems.
3. Min. loading is about 10%
4. Please try to use dimmers with power at least 1.5 times as the output power of the driver.

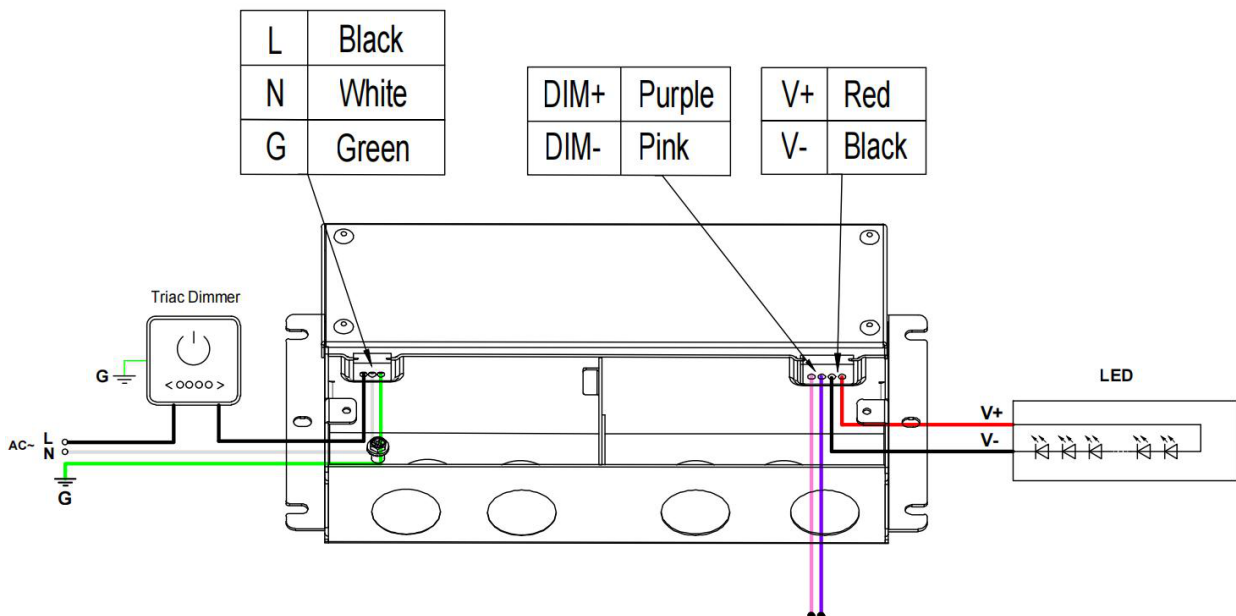

Project:	Type:
	Comments:

- Using one dimming --0-10/ 1-10V/ 10V PWM/ Potentiometer dimming

